

## Technical characteristics

Main power supply	220-230 Vac 50/60 Hz
Motor voltage	24Vdc
Maximum power consumption	300 W
Control board	Control Board Levixo 40/60
Obstacle detection	Encoder
Opening time	2,5 s to 6 s (Levixo 40) / 3 s to 9 s (Levixo 60)
Boom length	4 m without accessories (Levixo 40) / 6 m without accessories (Levixo 60)
Operating temperature	-20° to +55°
Maximum number of operations/day	2000
Index of protection	IP 54
Weight (without boom)	40 kg

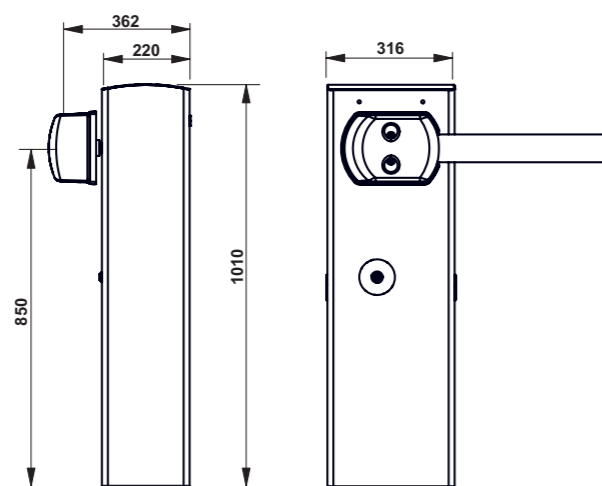

## Booms and fixation kits

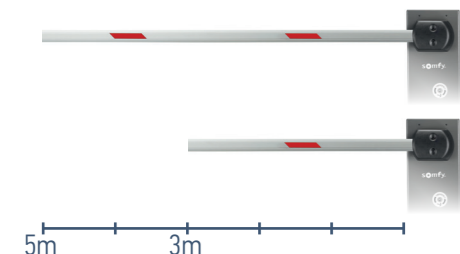

Rectangular boom

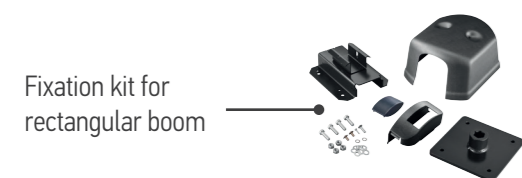

Fixation kit for rectangular boom

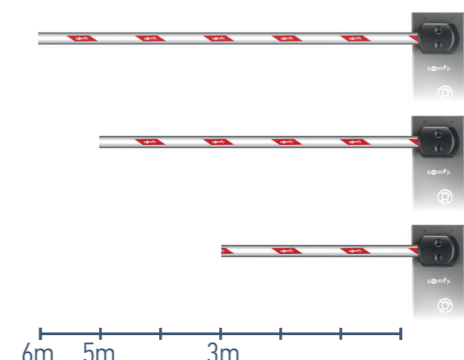

Rounded boom

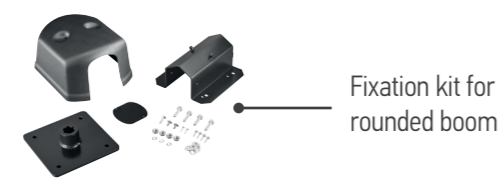

Fixation kit for rounded boom

## Length of boom

		BOOM ACCESSORIES									
Rubber under boom (Ref. 9017045)			•	•	•		•	•	•		
Rubber over boom (Ref. 9017045)			•	•			•	•			
Led lighting kit (Ref. 9020718)			•				•				
Rest crutch (Ref. 9020720)			•	•	•	•					
LEVIXO 60	H3	L min	4,7 m	4,2 m	4,3 m	4,5 m	4,8 m	4,6 m	4,7 m	5 m	
		L max	6 m	5 m	5 m	5 m	5 m	5 m	5 m	5 m	5 m
	H2	L min	4,1 m	2,6 m	3 m	3,2 m	3,4 m	3,3 m	3,4 m	3,6 m	
		L max	4,6 m	4 m	4,1 m	4,4 m	4,7 m	4,4 m	4,6 m	4,7 m	
LEVIXO 40	H3	L min	3,8 m	2,8 m	2,8 m	2,8 m	2,8 m	2,8 m	2,8 m	2,8 m	
		L max	4 m	4 m	4 m	4 m	4 m	4 m	4 m	4 m	4 m
	H2	L min	2,9 m	2,2 m	2,3 m	2,5 m	2,6 m	2,6 m	2,6 m	2,6 m	
		L max	3,7 m	2,7 m	2,7 m	2,7 m	2,7 m	2,7 m	2,7 m	2,7 m	
H1	L min	2,1 m	1,4 m	1,4 m	1,5 m	1,6 m	1,7 m	1,8 m	1,9 m		
	L max	3 m	2,2 m	2,3 m	2,5 m	2,6 m	2,6 m	2,7 m	2,7 m		

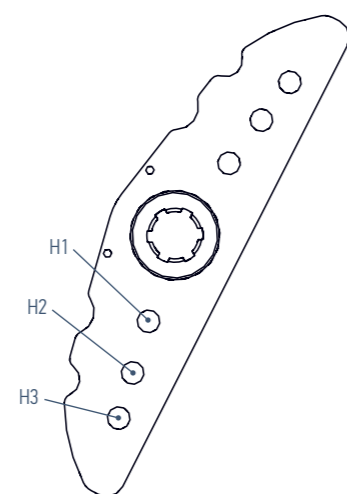

**Somfy**  
50 avenue du Nouveau Monde  
74300 CLUSES  
FRANCE  
T +33 (0)4 50 96 70 00  
F +33 (0)4 50 96 71 89  
[www.somfy.com](http://www.somfy.com)

A BRAND OF **SOMFY** GROUP

**Levixo 24V**  
BARRIER FOR VEHICLE



Fast, intensive & reliable  
MADE FOR THE COLLECTIVE



Somfy - Photos: Semaphore, Adrien Dasté, Stéphane Rambaud - SOMFY ACTIVITIES SA, Société Anonyme, capital 35.000.000 Euros, RCS Annecy, 383.970.230 - ©SOMFY.COM - Octobre 2017



## Somfy, your preferred partner

With more than 50 years by your side, Somfy is one of the top European leaders in the automatic control of openings and closures in homes and buildings. Because your comfort is our priority, our local teams are at your side supported by a R&D center in Europe.

## A dedicated range for your applications

Our barriers are suitable for both semi-intensive and intensive use, thanks to their motorisations in 230V and 24V. Our 3m and 5m rectangular booms and our 3m, 5m, and 6m rounded booms will adapt to your every need.



## LEVIXO 24V Benefit from all of its advantages

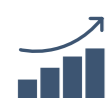

### An intensive use for the collective

- Up to **2000 openings/closings** per day thanks to the 24V motor.
- **Adjustable settings** for collective needs such as courtesy light, pre signal or fast closing !
- **Robust barrier and control board** are compatible with **various accessories** such as orange light, led lights and rest crutch.



### The barrier to answer to all your needs

- **Fast speed** for an opening in 2,5 secondes.
- **Compatible** with rectangular or rounded boom up to 6 meters length.
- **More than 40 settings adjustable** including deceleration, acceleration, brake force and speed.
- **Unlock** with standard key to declutch the motor and protect the installation.
- **Compatible with a timer and other accessories** thanks to its two output contacts.



### A personalised solution for all your installations !

- **Only one reference** of product for a left or right barrier.
- **Easy installation** thanks to its wide opening for cable passage, its removable door and internal space giving great freedom of movement during the installation.
- **A robust barrier** with a steel casing.

## READY TO DISCOVER THE SOMFY BARRIER OFFER ?

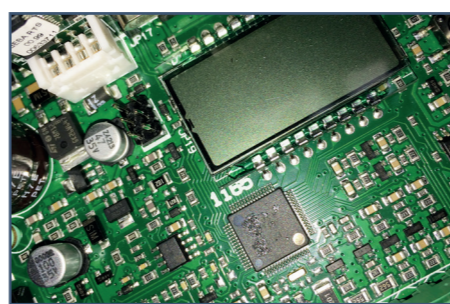
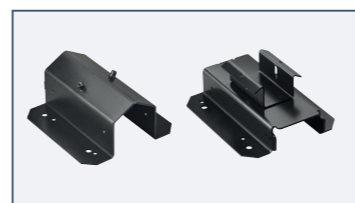
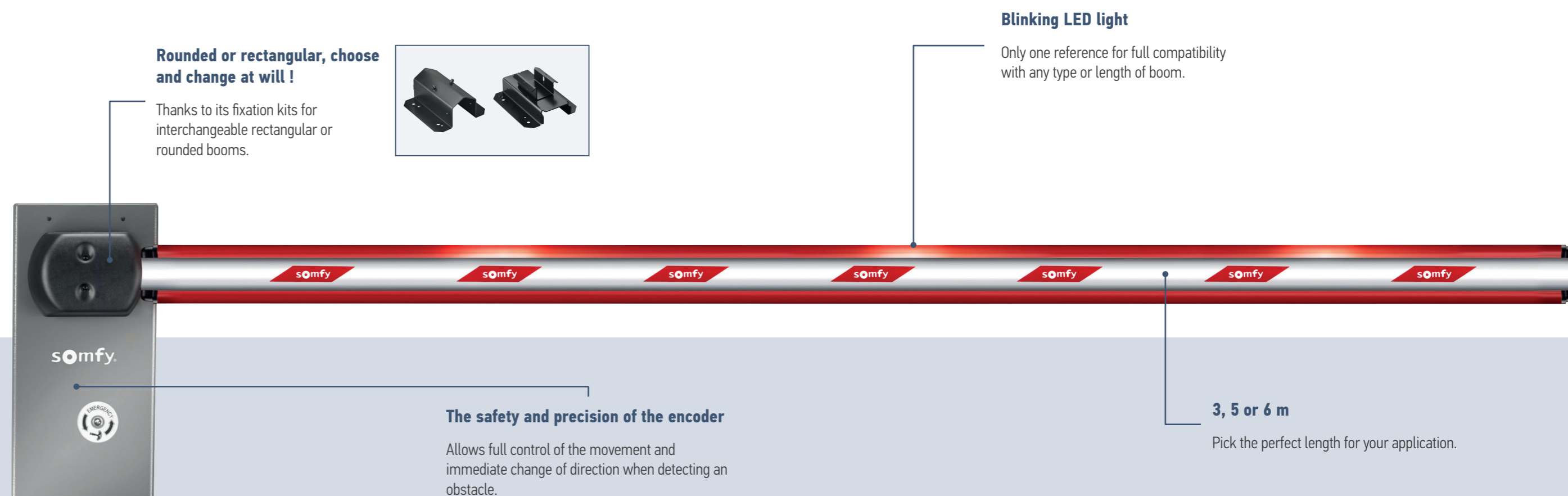

## Accessories

